

GaAs MMIC

Data Sheet

CGY 60

- Low noise preamplifier for mobile communication (PCN, DECT, GSM) in 2.7 V to 6 V systems
- Biased monolithic microwave IC (MMIC) matched to 50 Ω for 1.7 to 2 GHz
- Easily matchable to 50 Ω for lower frequencies (i.e. GSM-application)
- No bias coil needed
- Low noise figure and high gain (typ. NF = 1.9 dB, $G = 12.5$ dB @ 3 V, 1.85 GHz)
- Low power consumption
- Frequency range 200 MHz ... 2.5 GHz

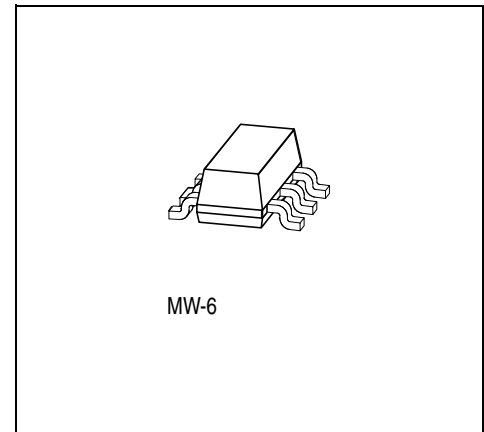

ESD: Electrostatic discharge sensitive device,
observe handling precautions!

Type	Marking	Ordering Code (taped)	Package ¹⁾
CGY 60	Y7s	Q62702-G39	MW-6

¹⁾ Dimensions see **Page 10**.

Maximum Ratings

Parameter	Symbol	Value	Unit
Drain voltage	V_D	8	V
Channel temperature	T_{Ch}	150	$^{\circ}\text{C}$
Storage temperature range	T_{stg}	- 55 ... + 150	$^{\circ}\text{C}$
Total power dissipation ($T_S \leq 132$ $^{\circ}\text{C}$) ¹⁾	P_{tot}	80	mW

¹⁾ Please care for sufficient heat dissipation on the pcb!

Thermal Resistance

Parameter	Symbol	Value	Unit
Channel-soldering point (GND)	R_{thChS}	≤ 220	K/W
Channel-ambient ¹⁾	R_{thChA}	< 300	K/W

¹⁾ Package mounted on alumina 15 mm \times 16.7 mm \times 0.7 mm.

Electrical Characteristics of CGY 60 in GSM Application Circuit
 $T_A = 25\text{ }^\circ\text{C}$, $f = 950\text{ MHz}$, $R_S = R_L = 50\text{ }\Omega$, unless otherwise specified.

Characteristics	Symbol	Limit Values			Unit
		min.	typ.	max.	
Drain current	I_D	–	6	9	mA
Power Gain	G				dB
$V_D = 3\text{ V}$		–	15.5	–	
$V_D = 5\text{ V}$		–	17	–	
Noise figure	F				dB
$V_D = 3\text{ V}$		–	1.35	–	
$V_D = 5\text{ V}$		–	1.30	–	
Input return loss	RL_{IN}				dB
$V_D = 3\text{ V}$		–	10	–	
$V_D = 5\text{ V}$		–	10	–	
Output return loss	RL_{OUT}				dB
$V_D = 3\text{ V}$		–	11	–	
$V_D = 5\text{ V}$		–	11	–	
Third order input intercept point two-tone intermodulation test $f_1 = 950\text{ MHz}$, $f_2 = 951\text{ MHz}$ $P_{IN} = -20\text{ dBm}$ (both carriers)	IP_3				dBm
$V_D = 3\text{ V}$		–	-3	–	
$V_D = 5\text{ V}$		–	-1	–	
Input power at 1 dB gain compression	$P_{-1\text{ dB}}$				dBm
$V_D = 3\text{ V}$		–	-10	–	
$V_D = 5\text{ V}$		–	-8	–	

Electrical Characteristics in PCN-, DECT-Application Circuit
 $T_A = 25\text{ °C}$, $f = 1850\text{ MHz}$, $R_S = R_L = 50\ \Omega$, unless otherwise specified.

Characteristics	Symbol	Limit Values			Unit
		min.	typ.	max.	
Drain current	I_D	–	6	9	mA
Power Gain	G				dB
$V_D = 3\text{ V}$		–	12.5	–	
$V_D = 5\text{ V}$		–	13.5	–	
Noise figure	F				dB
$V_D = 3\text{ V}$		–	1.90	–	
$V_D = 5\text{ V}$		–	1.85	–	
Input return loss	RL_{IN}				dB
$V_D = 3\text{ V}$		–	14.5	–	
$V_D = 5\text{ V}$		–	14.5	–	
Output return loss	RL_{OUT}				dB
$V_D = 3\text{ V}$		–	14	–	
$V_D = 5\text{ V}$		–	14	–	
Third order input intercept point two-tone intermodulation test $f_1 = 1850\text{ MHz}$, $f_2 = 1851\text{ MHz}$ $P_{IN} = -20\text{ dBm}$ (both carriers)	IP_3				dBm
$V_D = 3\text{ V}$		–	0	–	
$V_D = 5\text{ V}$		–	2	–	
Input power at 1 dB gain compression	$P_{-1\text{ dB}}$				dBm
$V_D = 3\text{ V}$		–	–7	–	
$V_D = 5\text{ V}$		–	–5	–	

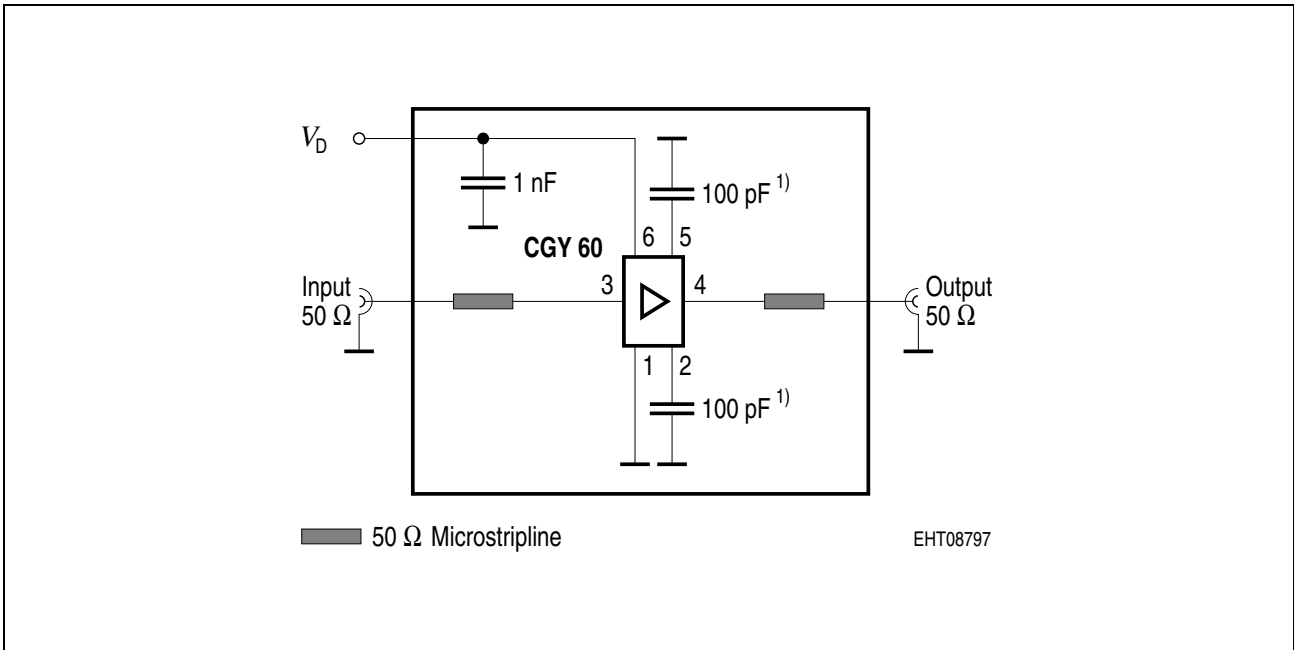

Figure 1 Application Circuit for Measuring S- and Noise-Parameters
 $f = 200 \text{ MHz to } 2 \text{ GHz}$

1) Use 12 to 15 pF for DECT - or PCN - applications.

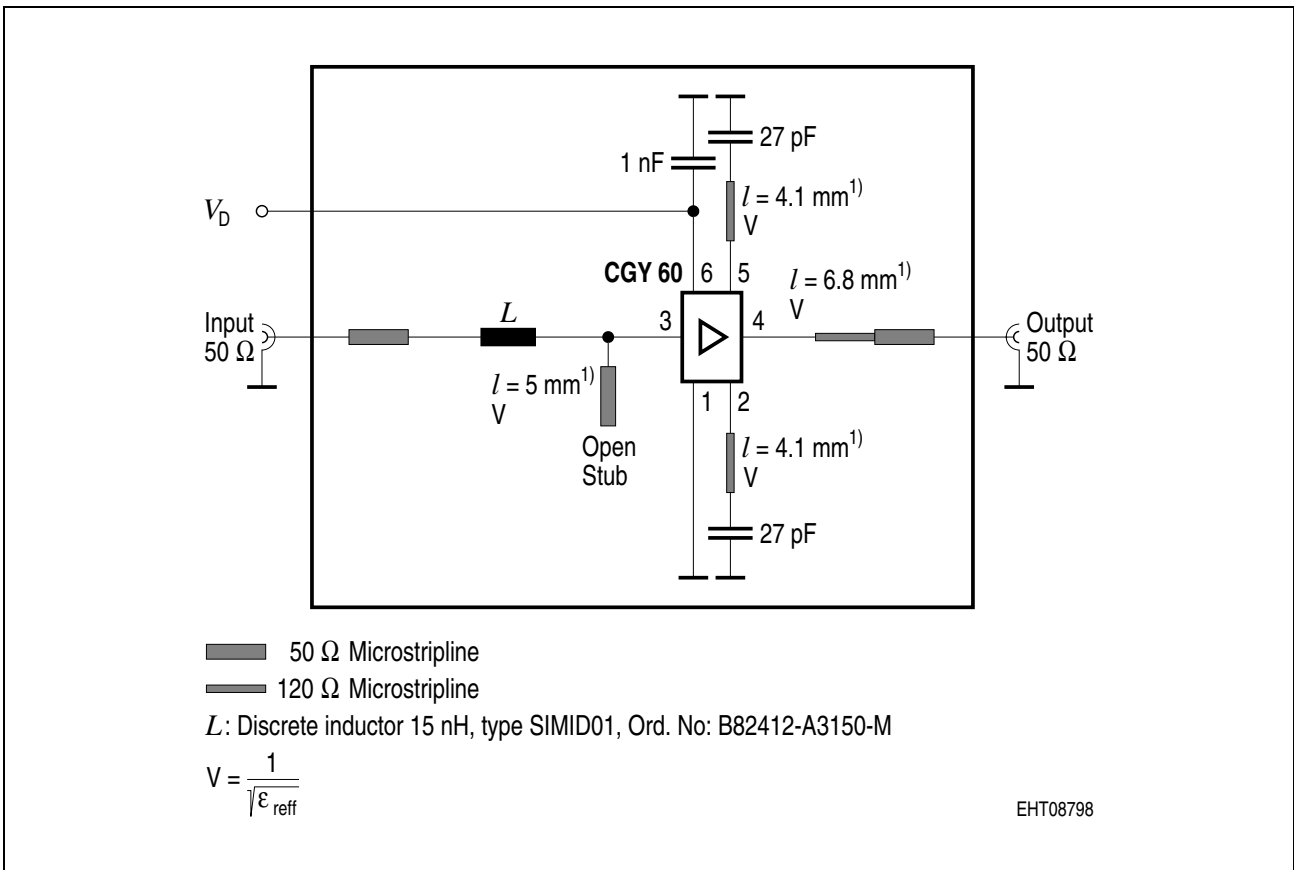

Figure 2 900 MHz Application (GSM)

PCB - Layouts for Application Circuits

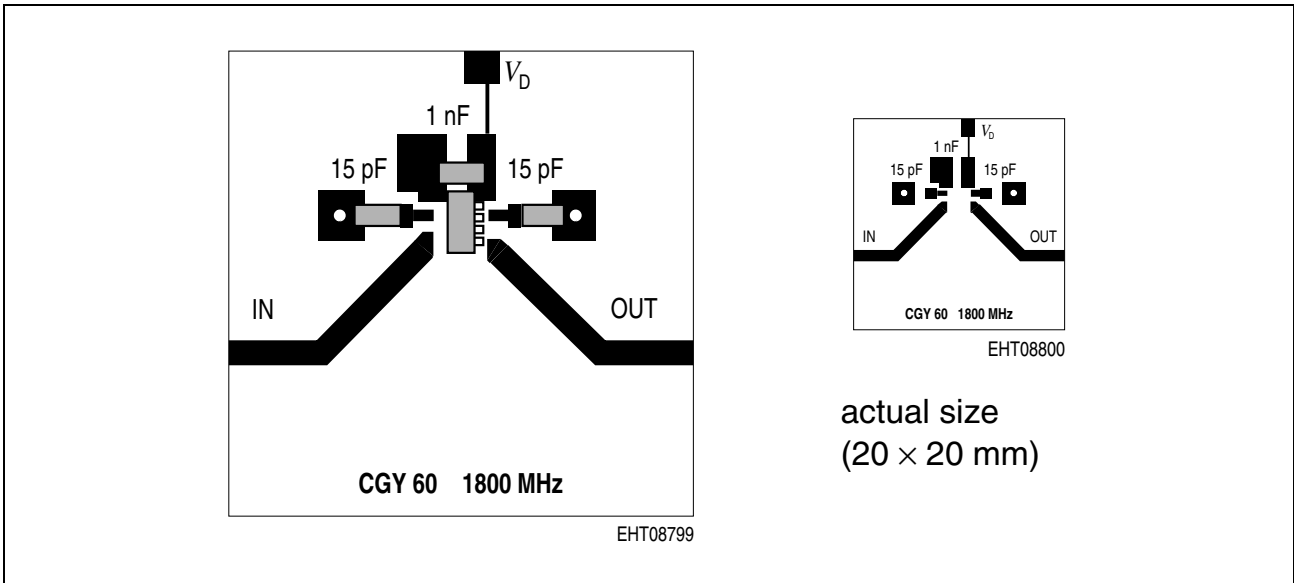

Figure 3 PCN -, DECT - Application Board

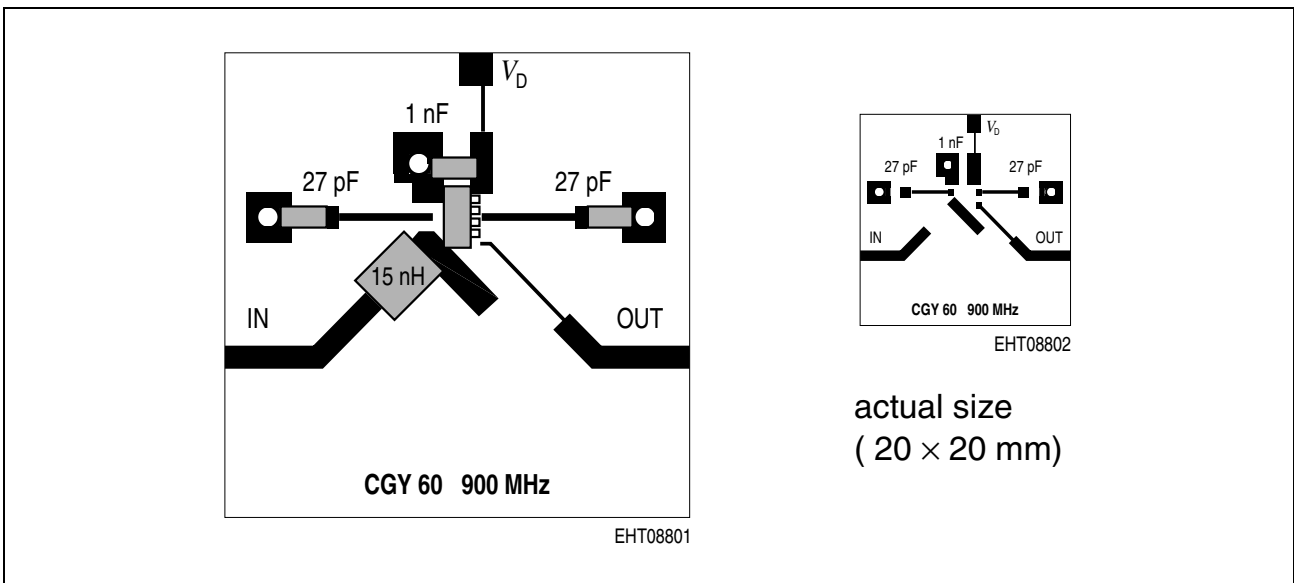

Figure 4 GSM - Application Board

PCB - data: Glass fiber teflon board (double sided) TACONIC TLX-9-0150-CH/CH.

$\epsilon_r = 2.45$, thickness = 0.4 mm

Typical S- and Noise-Parameters

$V_D = 3 \text{ V}, Z_0 = 50 \Omega$

<i>f</i>	S11		S21		S12		S22	
GHZ	MAG	ANG	MAG	ANG	MAG	ANG	MAG	ANG
0.1	0.97	- 5	2.98	- 135	0.005	80	0.74	- 34
0.2	0.97	- 9	3.85	- 162	0.009	77	0.51	- 44
0.3	0.96	- 14	4.13	- 177	0.013	74	0.41	- 47
0.4	0.94	- 19	4.27	172	0.017	73	0.35	- 48
0.5	0.93	- 23	4.35	163	0.021	71	0.33	- 49
0.6	0.91	- 29	4.40	155	0.026	67	0.31	- 51
0.7	0.88	- 34	4.45	148	0.029	65	0.30	- 54
0.8	0.85	- 40	4.48	140	0.033	63	0.29	- 58
0.9	0.81	- 46	4.51	132	0.037	60	0.29	- 63
1.0	0.76	- 52	4.55	125	0.042	54	0.28	- 69
1.1	0.71	- 59	4.60	117	0.045	50	0.27	- 74
1.2	0.64	- 66	4.62	110	0.048	46	0.26	- 80
1.3	0.58	- 74	4.63	102	0.051	41	0.26	- 86
1.4	0.51	- 83	4.61	94	0.053	36	0.25	- 93
1.5	0.43	- 93	4.58	85	0.054	31	0.24	- 101
1.6	0.34	- 106	4.51	77	0.055	26	0.23	- 109
1.7	0.26	- 122	4.40	69	0.055	20	0.22	- 118
1.8	0.19	- 149	4.30	60	0.054	15	0.21	- 128
1.9	0.15	172	4.13	51	0.051	11	0.20	- 140
2.0	0.18	131	3.94	43	0.049	5	0.19	- 151
2.1	0.24	106	3.73	35	0.046	2.5	0.18	- 163
2.2	0.32	90	3.56	27	0.043	- 5	0.18	177
2.3	0.39	78	3.33	20	0.038	- 9	0.18	170
2.4	0.46	69	3.09	13	0.033	- 11	0.18	160
2.5	0.52	61	2.87	5	0.028	- 12	0.19	151

f	F_{\min}	Γ_{opt}		R_N
		MAG	ANG	
GHz	dB	–	deg	Ω
0.9	1.27	0.70	27	47.8
1.3	1.35	0.63	39	32.7
1.8	1.50	0.42	59	18.2
2.0	1.60	0.30	62	15.0

Typical S- and Noise-Parameters
 $V_D = 3 \text{ V}, Z_0 = 50 \Omega$

f	S11		S21		S12		S22	
	MAG	ANG	MAG	ANG	MAG	ANG	MAG	ANG
0.1	0.97	– 4	3.58	– 137	0.005	74	0.72	– 31
0.2	0.97	– 9	4.49	– 164	0.009	75	0.52	– 37
0.3	0.96	– 14	4.78	– 178	0.013	74	0.44	– 38
0.4	0.94	– 18	4.91	171	0.017	71	0.39	– 39
0.5	0.93	– 23	4.96	163	0.021	70	0.37	– 40
0.6	0.90	– 28	5.02	154	0.024	67	0.36	– 42
0.7	0.88	– 34	5.09	147	0.028	64	0.35	– 45
0.8	0.85	– 39	5.11	139	0.032	62	0.34	– 50
0.9	0.81	– 45	5.14	132	0.036	60	0.34	– 54
1.0	0.76	– 51	5.16	125	0.041	55	0.33	– 59
1.1	0.71	– 58	5.23	118	0.044	50	0.32	– 64
1.2	0.65	– 65	5.25	110	0.046	45	0.31	– 70
1.3	0.59	– 72	5.25	102	0.049	42	0.30	– 75
1.4	0.52	– 81	5.25	95	0.050	37	0.29	– 81
1.5	0.44	– 90	5.21	87	0.052	32	0.27	– 88
1.6	0.36	– 103	5.15	78	0.052	27	0.26	– 95
1.7	0.28	– 118	5.05	70	0.052	23	0.24	– 102

Typical S- and Noise-Parameters (cont'd)
 $V_D = 3 \text{ V}, Z_0 = 50 \Omega$

<i>f</i>	S11		S21		S12		S22	
	MAG	ANG	MAG	ANG	MAG	ANG	MAG	ANG
1.8	0.20	- 140	4.93	62	0.051	17	0.22	- 111
1.9	0.16	- 176	4.77	53	0.050	13	0.20	- 121
2.0	0.17	141	4.57	45	0.047	8	0.18	- 131
2.1	0.23	113	4.36	37	0.045	5	0.17	- 142
2.2	0.31	95	4.18	29	0.042	- 2	0.16	- 158
2.3	0.38	82	3.92	21	0.037	- 6	0.14	- 173
2.4	0.45	72	3.66	14	0.032	- 8	0.14	174
2.5	0.52	64	3.39	7	0.027	- 9	0.14	162

<i>f</i>	F_{\min}	Γ_{opt}		R_N
		MAG	ANG	
GHz	dB	-	deg	Ω
0.9	1.23	0.69	26	47.7
1.3	1.32	0.67	39	33.3
1.8	1.45	0.45	55	18.6
2.0	1.53	0.32	60	15.2

Package Parameters

Dim.	min.	nom.	max.	Gradient	Remark
A	–	–	1.1	–	–
A ₁	–	–	0.1	–	–
A ₂	–	–	1.0	–	–
b	–	0.3	–	–	–
b ₁	–	0.6	–	–	–
c	0.08	–	0.15	–	–
D	2.8	–	3.0	–	–
E	1.2	–	1.4	–	–
lel	–	0.95	–	–	–
le ₁ l	–	1.9	–	–	–
H _E	–	–	2.6	–	–
L _E	–	–	0.6	–	–
a	–	–	–	max 10°	1)
q	–	–	–	2° ... 30°	–

1) Applicable on all case top sides.

Package Outlines

MW-6
(Special Package)

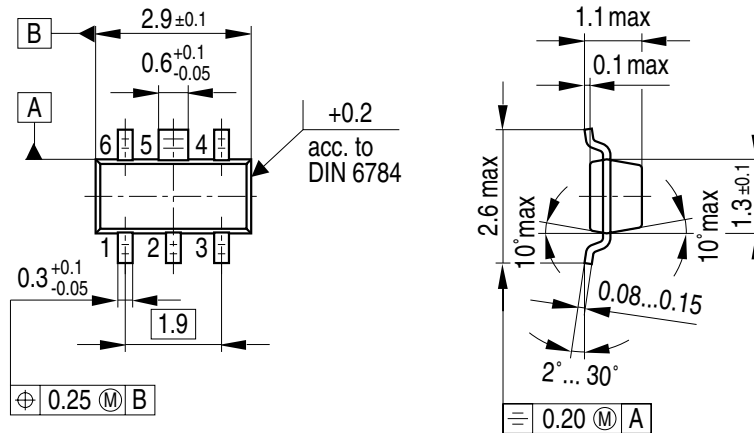

GPW05794

Sorts of Packing

Package outlines for tubes, trays etc. are contained in our Data Book "Package Information".

SMD = Surface Mounted Device

Dimensions in mm